



# MIX FLOW

INDUSTRIAL VALVE SOLUTION

**Butterfly  
valves**

**INFLATABLE  
soft seated**

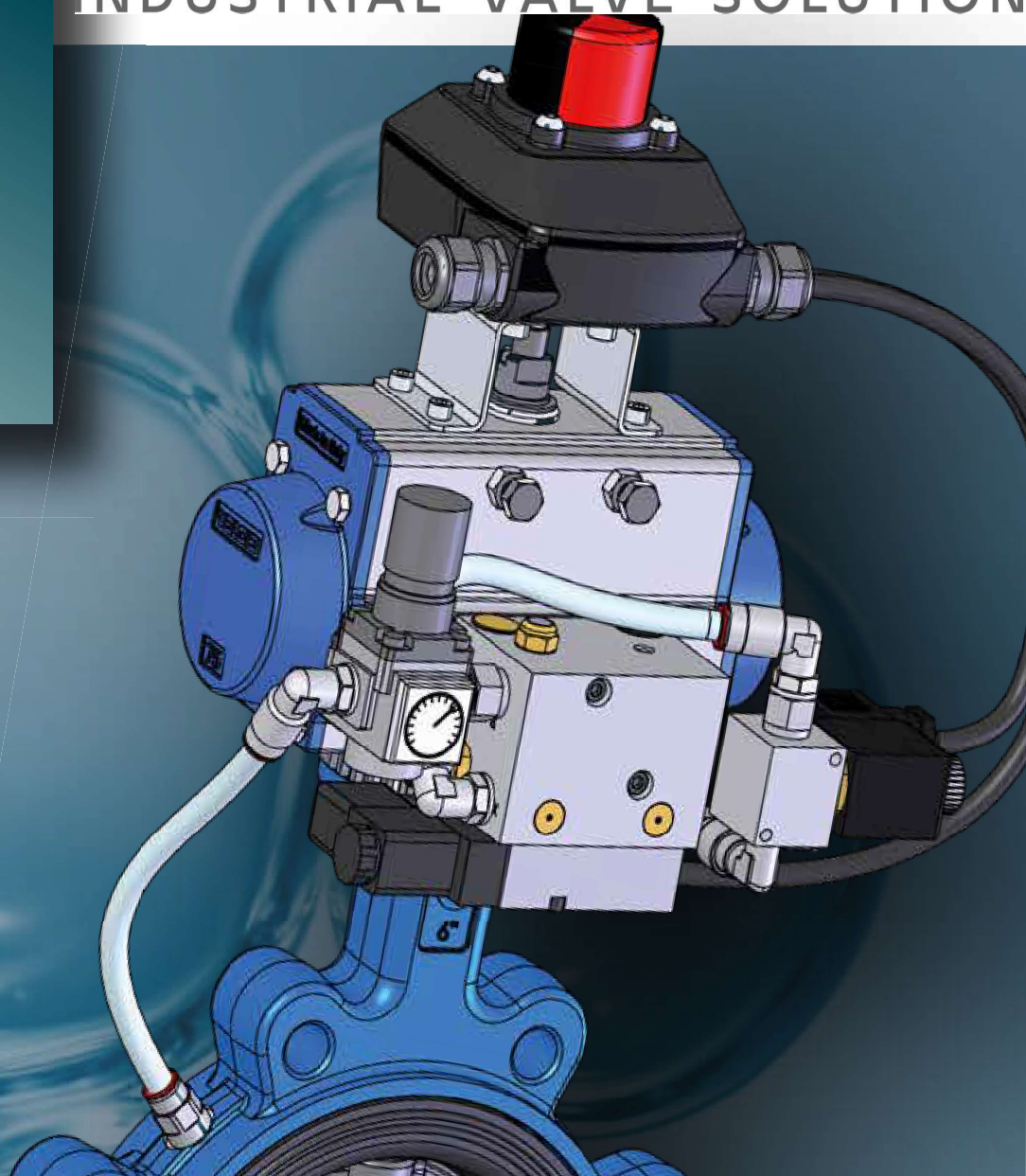

INDUSTRIAL VALVE SOLUTION



Grupa Baltina [www.mixflow.com.pl](http://www.mixflow.com.pl)

**MIXFLOW – ENERGY**

PL 80 – 314 Gdańsk,

Al. Grunwaldzka 303

Tel: +48 58 676 55 39

[info@mixflow.com.pl](mailto:info@mixflow.com.pl)



**For powder  
and abrasive  
applications**

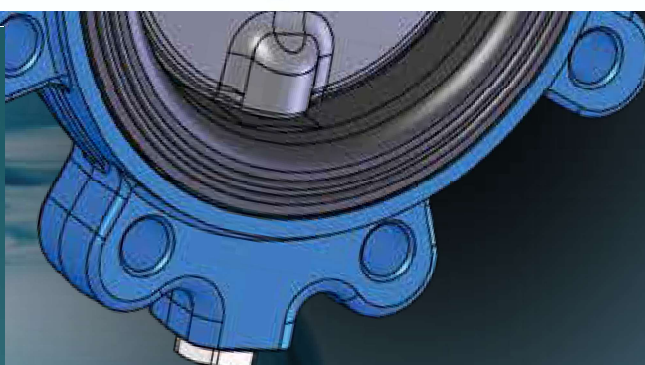



**BVDL - Wafer BLDL - Lug**  
**DN 50 - 500 • 2" - 20"**

**Only complete package available  
 (with actuation system included).  
 Bare shaft configuration not salable.**

**Max working pressure:**

BVDL/BLDL DN 50÷500: **6 Bar**  
 Flange: **PN 6 - 10 - 16 • A150**

**Design:**

EN 593 ~ EN 736 ~ EN 12516 ~ EN 1092  
 ISO 5211 ~ DIN 3337 ~ API 609  
 PED 2014/68/EU - Mod. H

**Face to face:**

DIN EN 558 Series 20 ~ ISO 5752 Series 20  
 BS-5155 Series 4 ~ MSS-SP67  
 API609 cat.A ~ NFE 29305-1

**Feeding pressure for actuating system:**

Min: 5bar ~ Max: 8 bar

**Feeding tension for actuating system:**

24 VDC ~ 110 VAC ~ 230VAC  
 To be defined in the order

**Testing:**

EN 12266-1 Rate A (supersedes DIN 3230)  
 ISO 5208 Rate A ~ API 598

**Tag:**

EN 19 ~ MSS SP-25

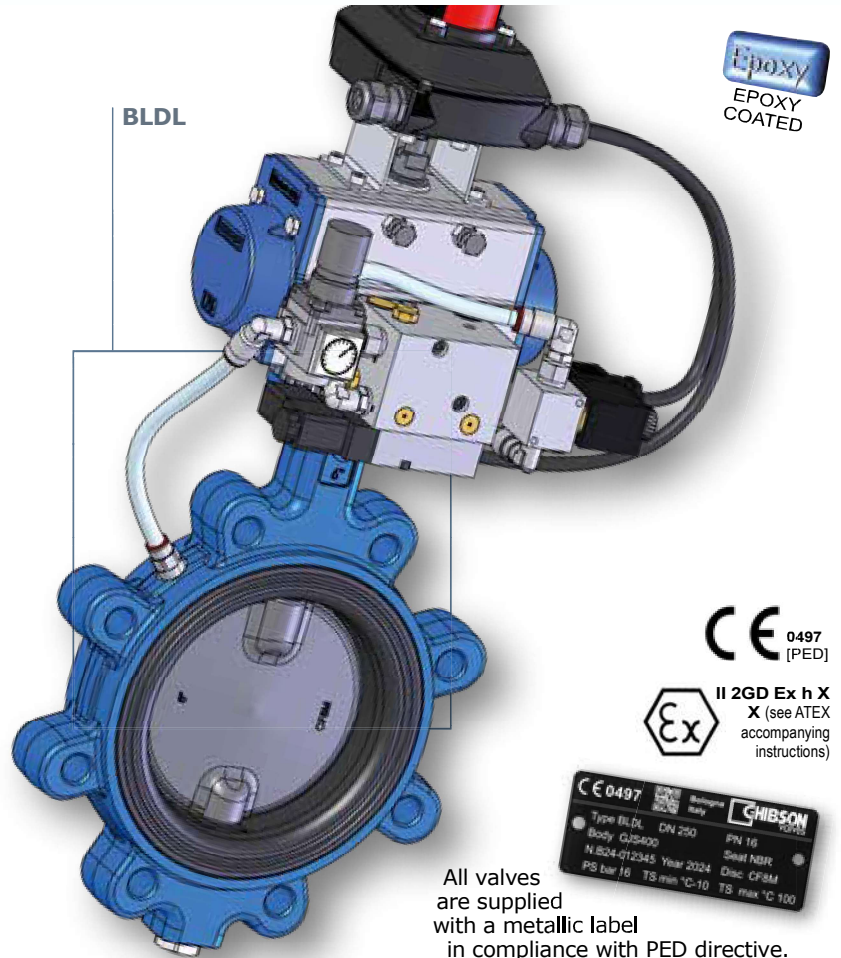

All valves are supplied with a metallic label in compliance with PED directive.

BODY *			
material	references	standard coating	DN
Ductile iron	EN-GJS 400-15 (GS400)	Epoxy RAL 5009	50-500
Carbon steel	ASTM A216-WCB	Epoxy RAL 9005	50-500
Stainless steel	ASTM A351 CF8M (A316)	-	50-500
Aluminium	EN AB 46400	Epossidico RAL 7024	50-500 only wafer

DISC *			
material	references	standard coating	DN
Stainless steel	ASTM A351 CF8M (A316)	-	50-500

BODY RUBBER SEAT *			
references	designation	trade name	working temp.
NBR	nitrile rubber	BUNA®	-25°C / +100°C
MVQ	silicon rubber	-	-60°C / +190°C
CO	carboxide	-	-25°C / +100°C
FKM	fluoroelastomer	VITON®	-20°C / +200°C

\* On request can be supplied other materials



**BVDL - Wafer BLDL - Lug**  
**DN 50 - 300 • 2" - 12"**  
**PN 6-10-16 • ANSI 150**

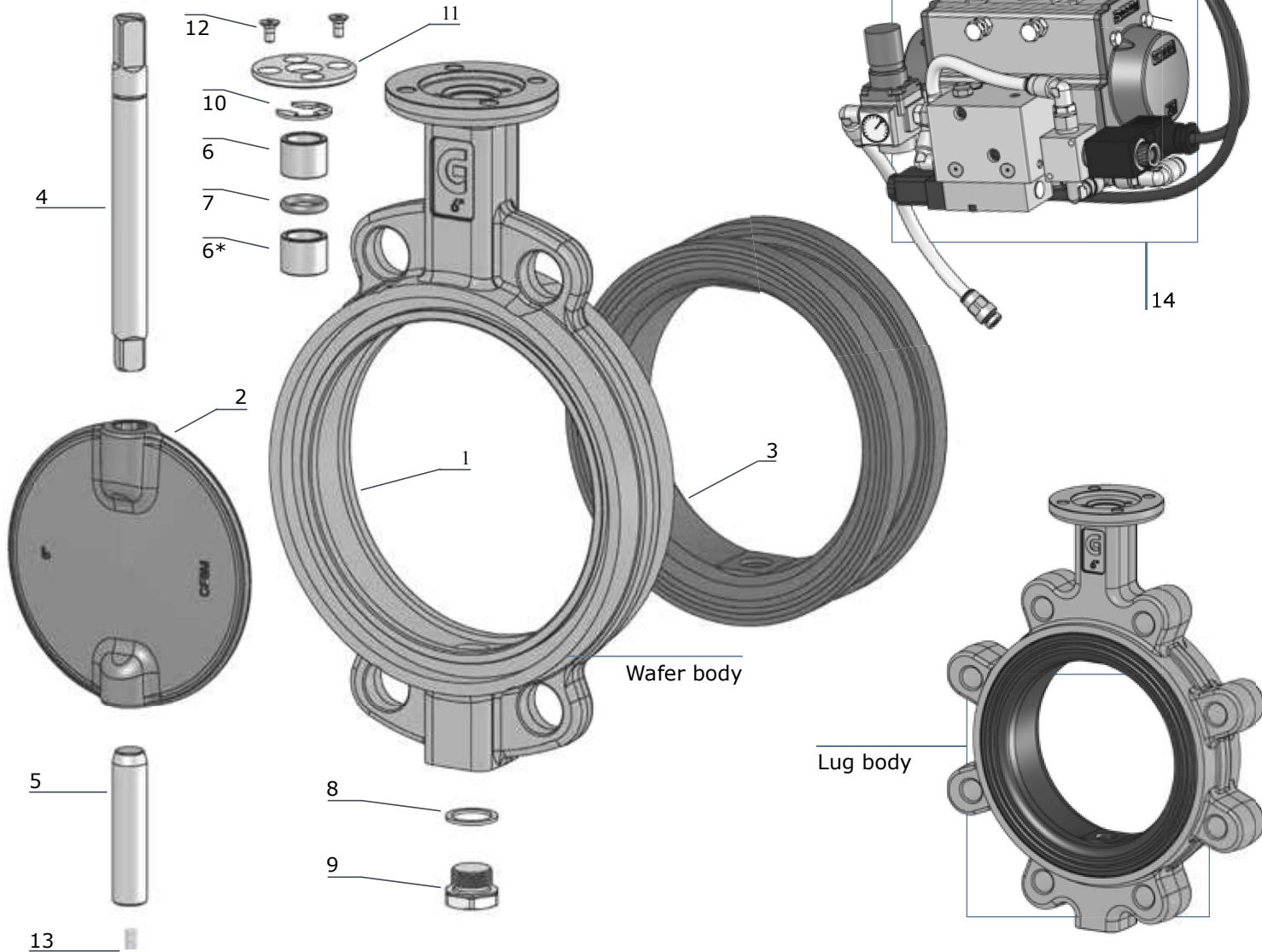

◇ parts included in spare kit \* only for DN300

item	q.ty	part	material
1	1	body	EN-GJS400-15 (GS400) EN 1.069~ A216-WCB 1.4408~ A351-CF8M (AISI 316) EN AB 46400 (only WAFER)
2	1	disc	EN 1.4408~ A351-CF8M
◇3	1	body seat (replaceable)	NBR (BUNA®) silicon rubber carboxide FKM (VITON®)
4	1	upper shaft	EN 1.4016~A430 EN 1.4401~A316 (on request)
5	1	lower shaft	EN 1.4016~A430 EN 1.4401~A316 (on request)
◇6	1	bush	bronze

item	q.ty	part	material
◇6*	6	bush	A105+PTFE A316+PTFE (only Inox body)
◇7	1	shaft packing	NBR (BUNA®) FKM (VITON®) on request
8	1	plug packing	aluminium PTFE (CF8M body)
9	1	threaded plug	zinc plated steel 1.4401~A316 (CF8M body)
10	1	stop ring	steel
11	1	upper flange	IXEF (DN 40-150) aluminium (DN 200-300)
12	2	screw	10.9 zinc plated steel A4~A316 (CF8M body)
13	1	spring	1.4401 ~ A316 (antistatic device)
14	1	Inflatable actuating system	



**BVDL - Wafer BLDL - Lug**  
**DN 350 - 500 • 14" - 20"**  
**PN 6-10-16 • ANSI 150**

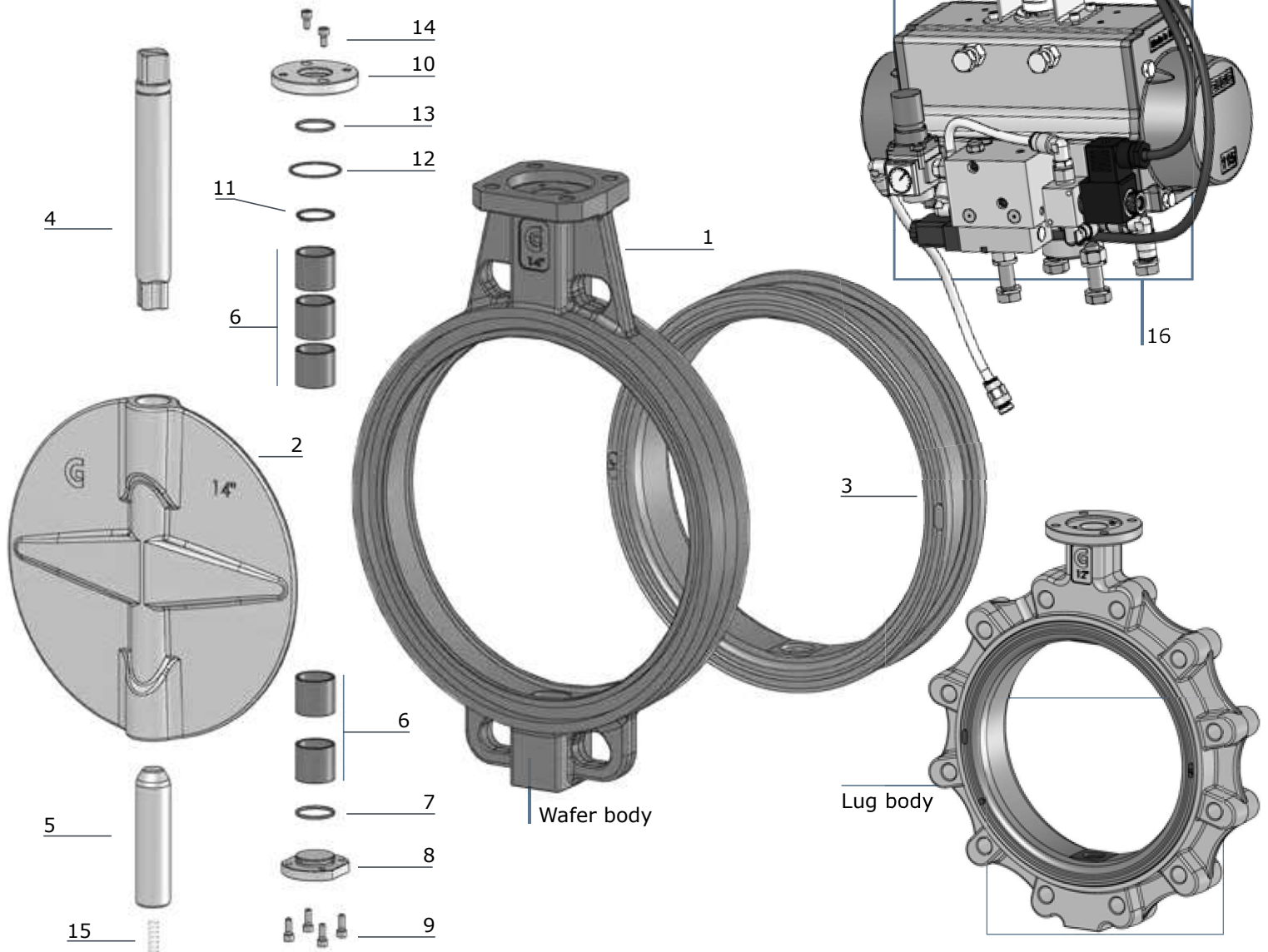

◇ parts included in spare kit

item	q.ty	part	material
1	1	body	EN-GJS400-15 (GS400) EN 1.069~ A216-WCB 1.4408~ A351-CF8M (AISI 316) EN AB 46400 (only WAFER)
2	1	disc	EN 1.4408~ A351-CF8M
◇3	1	body seat (replaceable)	NBR (BUNA®) silicon rubber carboxide FKM (VITON®)
4	1	upper shaft	EN 1.4016~A430 EN 1.4401~A316 (on request)
5	1	lower shaft	EN 1.4016~A430 EN 1.4401~A316 (on request)
◇6	5	bush	bronze steel+PTFE (DN 450-500)

item	q.ty	part	material
◇7	1	packing lower flange	NBR (BUNA®)
8	1	lower flange	zinc plated steel 1.4401~A316 (CF8M body)
9	4	screw	8.8 zinc plated steel A4~A316 (CF8M body)
10	1	upper flange	zinc plated steel 1.4401~A316 (CF8M body)
11	1	stop ring	steel
◇12	1	O. ring	NBR (BUNA®)
◇13	1	O. ring	NBR (BUNA®)
14	2	screw	8.8 zinc plated steel A4~A316 (CF8M body)
15	1	spring	1.4401 ~ A316 (antistatic device)
16	1	Inflatable actuating system	



**BVDL - Wafer BLDL - Lug**  
**DN 50 - 500 • 2" - 20"**

**Pneumatic Seated Valves:**

- created for bulk handling, in which the disc geometry is studied to permit low torque open/close.
- the lower friction disc/seat highly reduces heavily wear of the seats over time.
- longer lifetime of the valves and possibility to use of smaller actuators guarantee economical and space advantage.
- easy installation with pre-packaged actuating solution.

**Operating principle**

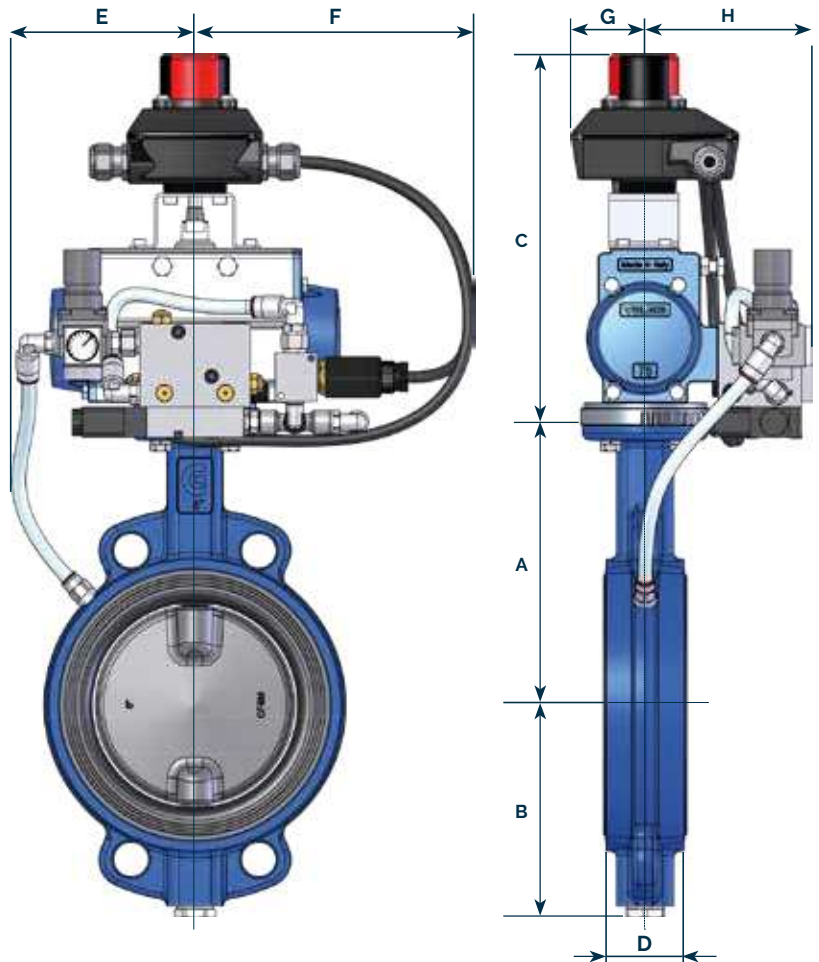
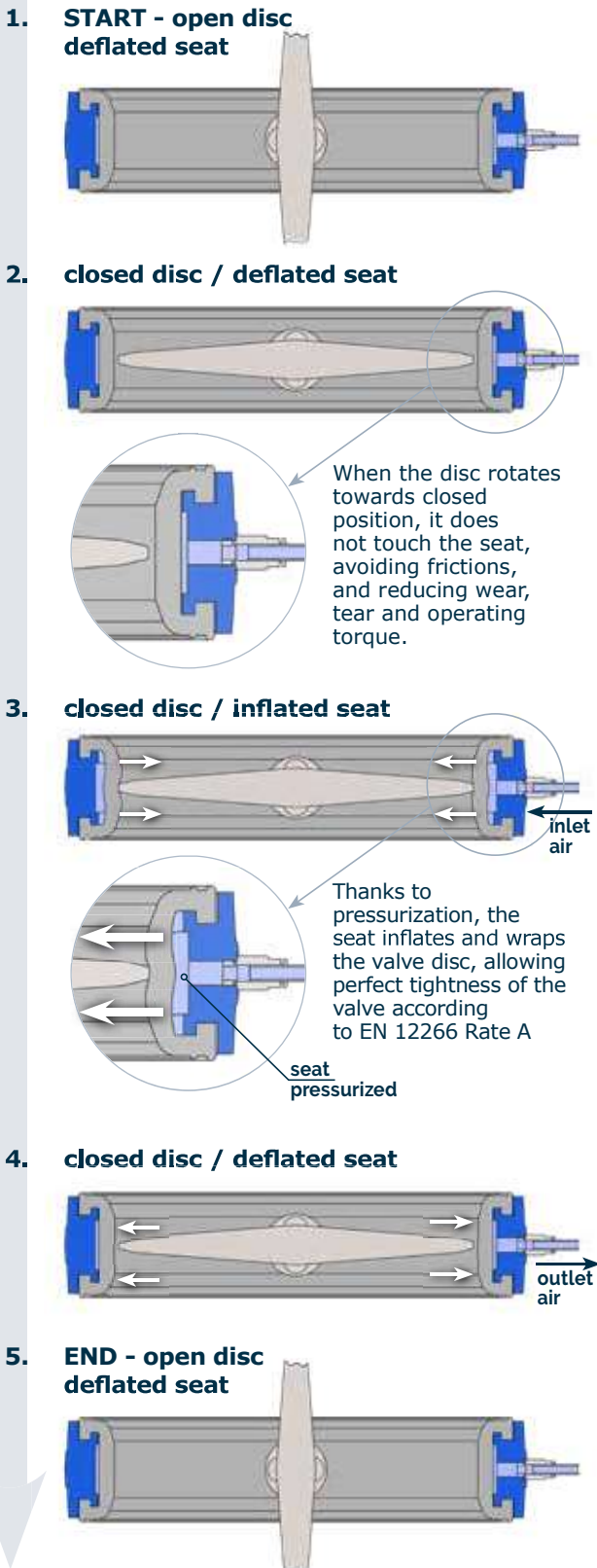

**Dimensions**

DN	A	B	C	D	E	F	G	H	VALBIA DOUBLE ACTING ACTUATOR SIZE
050	138	81	266	43	128	200	52	121	DA 75
065	144	98	266	46	128	200	52	121	
080	158	110	266	46	128	200	52	121	
100	173	128	266	52	128	200	52	121	
125	186	140	266	56	128	200	52	121	
150	202	155	266	56	128	200	52	121	DA 100
200	240	190	297	60	137	200	64	136	
250	270	220	297	68	137	200	64	136	
300	300	247	297	78	137	200	64	136	DA 115
350	330	280	352	78	166	200	66	141	
400	355	305	352	102	166	200	66	141	
450	400	343	364	114	186	200	87	148	DA 125
500	422	366	364	127	186	200	105	148	



## MORE THAN 40 YEARS OF HIGH QUALITY EXPERIENCE

Ghibson Italia can now boast of more than 40 years of experience in manufacturing of industrial valves. In these 40 years we have designed and manufactured in our facilities in Italy butterfly valves and check valves, for the most different industrial applications.

We export our products all over the world always providing our customers with the best assistance during all the phases: design, installation, maintenance.

## MARKET SEGMENTS and APPLICATIONS

Marine  
Water Treatment  
Pulp & Paper  
Power Plant  
Nuclear Plant  
HVAC  
Chemical & Petrochemical  
Powder Conveying Systems  
Food & Beverage

Steam isolation - Vacuum service - Refining  
Cooling Water systems - Metallurgical processes  
Powder transportation & storage  
Oil field recovery - Liquid natural gas  
Steam service - Steam Turbine  
Saltwater Service - District heating & cooling  
Hot Air & Smokes  
Chemicals storage & transportation  
Food & Beverage processes

### DEPARTMENTS

- RESEARCH & DEVELOPMENT
  - DESIGN
  - CUSTOMIZATION
  - PRODUCTION & LOGISTIC
  - SALES & MARKETING
- QUALITY CONTROL
  - CERTIFICATIONS
  - PACKING AND SHIPPING
  - AFTER SALES SUPPORT

## WIDE RANGE OF PRODUCTS

Very large choice of materials including valves of every alloy of carbon or stainless steel, bronze, aluminium, as well as with PTFE or Polypropylene.

We manufacture rubber seated valves with many elastomer types (EPDM, NBR, FKM, Silicone, Carboxidate among others), as well as PTFE, RTFE seated valves with many different coatings such as Halar, Rilsan, PFA, Chenisil, etc.

We can offer a total assistance:

- before selling we can start from dimensioning the valves and actuators, make selection of materials for all parts upon knowing the specification, prepare all types of drawings etc.
- after selling we make final documentation, provide installation supervision, undertake commissioning etc.

### BUTTERFLY VALVES

Rubber Seated  
PTFE Seated  
High Performance  
Damper Valves

### ACTUATORS & OPTIONS

Pneumatic - Electric -  
Hydraulic

### CONTROL SYSTEMS

### CUSTOMIZED VALVES

**CHECK VALVES**  
Disc type - Swing type  
Dual plate

INDUSTRIAL VALVE SOLUTION  
**MIX FLOW**  
Grupa Baltina [www.mixflow.com.pl](http://www.mixflow.com.pl)

**MIXFLOW – ENERGY**  
PL 80 – 314 Gdańsk,  
Al. Grunwaldzka 303  
Tel: +48 58 676 55 39  
[info@mixflow.com.pl](mailto:info@mixflow.com.pl)



## NOTES:

The valves presented in this catalog are manufactured in the EU by Ghibson Italia srl. according to our specifications