



INDUSTRIAL VALVE SOLUTION

MIX **FLOW**

Grupa Baltina www.mixflow.com.pl

MIXFLOW – ENERGY

PL 80 – 314 Gdańsk,

Al. Grunwaldzka 303

Tel: +48 58 676 55 39

info@mixflow.com.pl



 **Dival 500**

Pressure Regulators

Classification and Range of use

The **DIVAL 500** is a downstream direct-acting pressure regulator with balanced plug, for low, medium and high pressures.

Suitable for previously filtered, gaseous, non-corrosive liquids; thanks to the concept of a balanced plug, you can achieve a high flow rate coefficient, highly accurate (even at maximum flow rates), a lock up zone and relatively low lock up pressure, no internal leakage at zero flow rate and reduced response times.

The constancy of the regulated pressure and its accuracy, even with significant changes in the upstream pressure and/or flow rate, make the **DIVAL 500** regulator especially suitable for power distribution networks in civil and industrial plants.

It is built with a **TOP ENTRY** which gives the regulator important control advantages among which, for example, the ability to carry out full maintenance on it without removing it from the connection pipework.

The basic version of the **DIVAL 500** regulator is classified, according to European Standard **EN 334**, as a **Fail to Open** regulator.

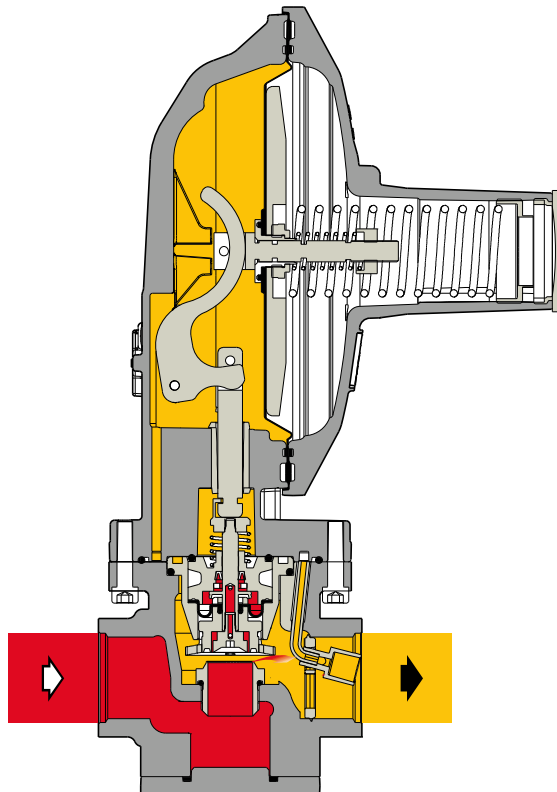

DIVAL - Basic version

FEATURES

Operating Features

- **Maximum inlet pressure:** 10 bar for BP version
20 bar for MP and TR versions
- **Downstream pressure regulation range:** from 15 to 2.500 mbar
- **AC accuracy class:** up to 5
- **SG lock up over pressure:** up to 10
- **Minimum environmental temperature:** Operation up to -40°C (to be specified in the request).
- **Maximum environmental temperature:** +60°C
- **Inlet gas temperature:** Up to -20°C +60°C (to be specified in the request).

Construction Features:

- **DN calibres available:** 25 (1"); 40 (1"1/2)
- **Connections:** See connections available on configurator

Materials: *

- **Body:** Cast Iron GJS 400-18 UNI EN 1563
Aluminium EN AC 43300 UNI EN 1706
ASTM A 216 WCB (All DN's).
- **Covers:** Aluminium EN AC 43500 UNI EN 1706
- **Diaphragm:** Fabric Finish Rubber (pre-formed using hot moulding process)
- **Seat:** Brass / Stainless steel
- **O-rings:** Nitrile rubber

NOTE: * The above materials refer to standard operations.
Different materials can be provided for specific needs.

MODULARITY AND ACCESSORIES

The **DIVAL 500** has been designed with a high degree of modularity for incorporating alternative devices and accessories in the basic version.

SHUT-OFF DEVICE model LA/...

This is a **Safety Accessory** that intercepts the gas flow when there are abnormal pressure conditions compared to that set during calibration of the dedicated pressure switch device.

Calibration can be varied at will, according to the operating requirements, within the ranges on the table below, depending on the pressure switch model provided.

For safety reasons the shut-off device can only be reset manually and inside the slam-shut there is a by-pass device that facilitates resetting.

The Accuracy class of the shut-off device is up to **AG 1**.

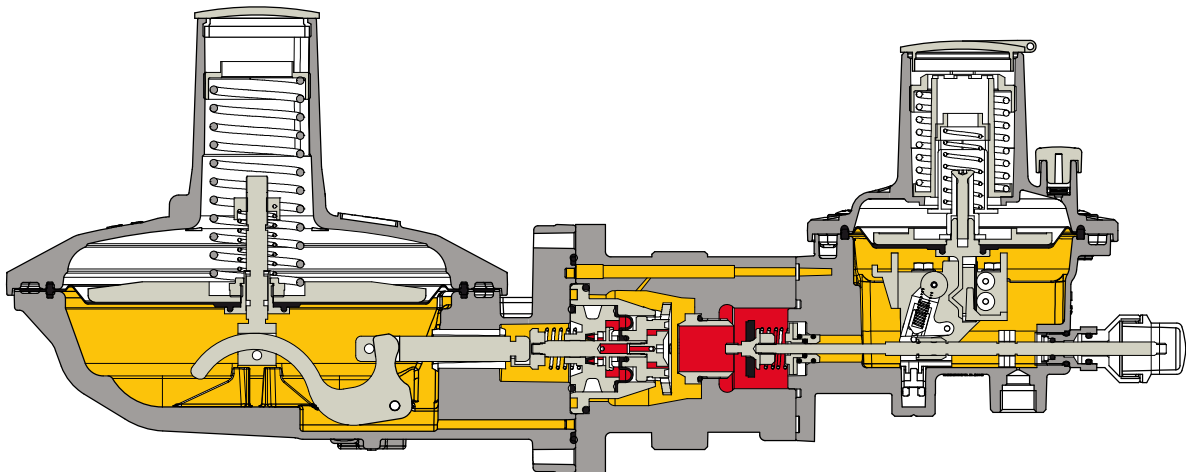

The shut-off device can be calibrated for pressure increase, **Over Pressure Shut-Off (OPSO)** and/or for pressure decrease, **Under Pressure Shut-Off (UPSO)**.

The two intervention modes can be calibrated independently by dedicated calibration springs: one spring for the maximum pressure intervention and the second spring for the minimum pressure intervention.

INCORPORATED RELIEF VALVE

The **Dival 500** series can be equipped with an incorporated relief valve that discharges the gas into the atmosphere when the regulator outlet pressure exceeds the set value. The events that can lead to the valve opening are:

- thermal expansion of the downstream gas in the absence of flow.
- pressure peaks caused by the downstream valve rapidly closing (in the event of small volumes).

When the outlet pressure returns to below the set value, the relief valve closes again.

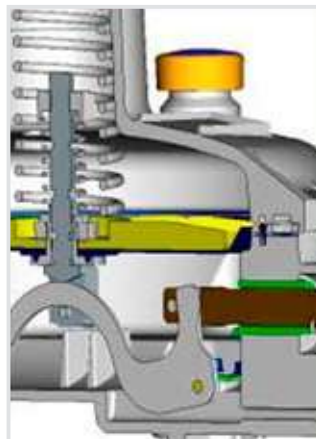

OPERATION AS A MONITOR

The **MONITOR** is a safety accessory that performs the functions of the service regulator when the main regulator fails.

This is a regulator valve that is usually fully open during normal operation of the service regulator. The **MONITOR** is an emergency pressure regulator that is usually upstream, in the direction of the gas flow, of another pressure regulator that performs the function of a **SERVICE** regulator.

So that a **DIVAL 500** regulator can perform the **MONITOR** function, restriction of the internal pressure tap and activation of only an external pressure tap must be foreseen.

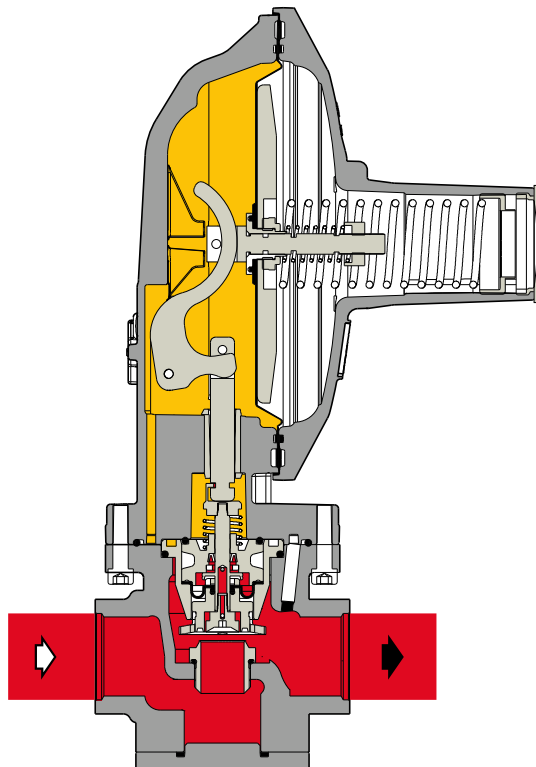

Control heads

The pressure ranges are determined by the control heads. The table below summarises the heads available and the obtainable regulated pressure ranges in mbar.

Regulator

Head	
BP	15 ÷ 100
MP	100 ÷ 300
TR	300 ÷ 2500

Shut-off device

Pressure switches	LA
Calibration range for pressure increase (OPSO)	30 ÷ 5500
Calibration range for pressure decrease (UPSO)	6 ÷ 3500

The obtainable pressure ranges are in mbar

Sizing the Pressure regulator

The regulator is usually chosen on the basis of the flow rate calculation determined through use of the flow rate coefficients (Cg or KG), as indicated by Standard EN 334.

However, the analytical calculation method does not correctly size the regulator as the obtainable theoretical flow rate should not be considered, but only a percentage of it, which is variable in every situation, based on the required accuracy class and the available pressure difference.

Please contact the sales office for correct sizing.

TYPICAL CONNECTION DIAGRAMS

The following examples are provided as a recommendation to get the best performance from the **DIVAL 500** regulator.

IN-LINE INSTALLATION

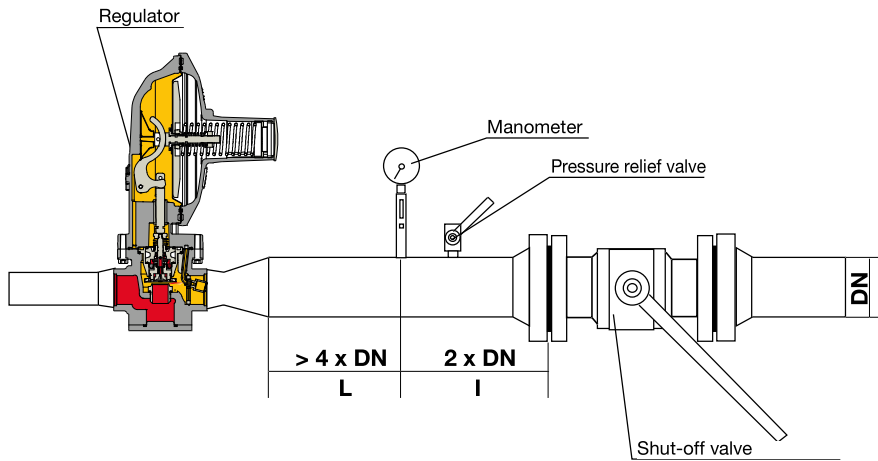

ANGLE INSTALLATION

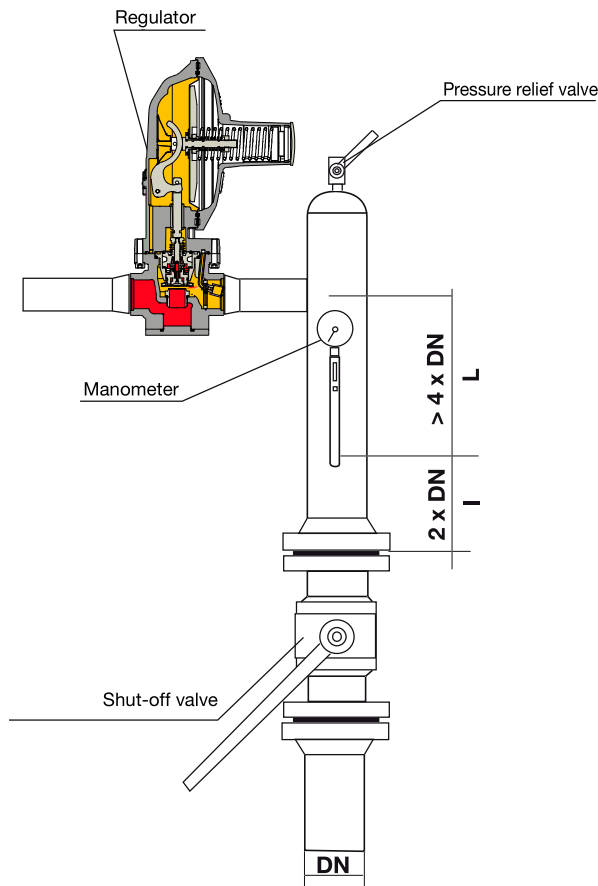

- Inlet pressure
- Outlet pressure

RECOMMENDED INSTALLATIONS

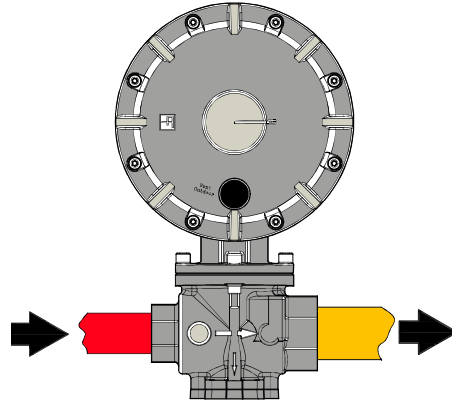

Basic position

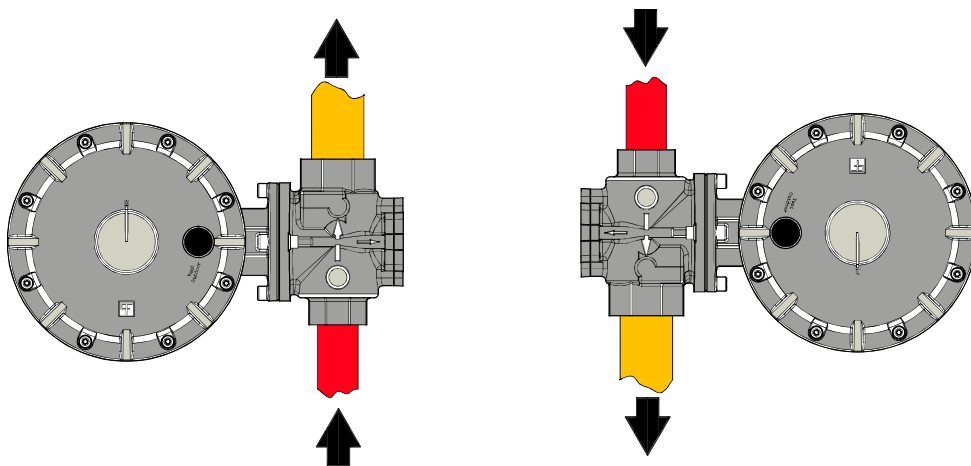

Vertical installation

DIVAL 500 DIMENSIONS

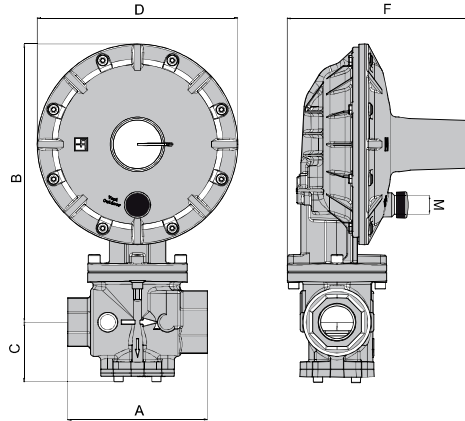

Overall dimensions in mm

Dival 500		
	Dival 500 1"x1"	Dival 500 1"x1 1/2"
A	100±1	130±1
B	255	257
C	44	55
D	185.5	185.5
F	173	173
DnE	1"ISO 7/1	1"ISO 7/1
DnU	1"ISO 7/1	1 1/2 ISO 7/1

Weights in KGF

	25	40
Inches	1"	1 1/2"
Dival 500	3.6	3.8

DIVAL 500 DIMENSIONS + LA

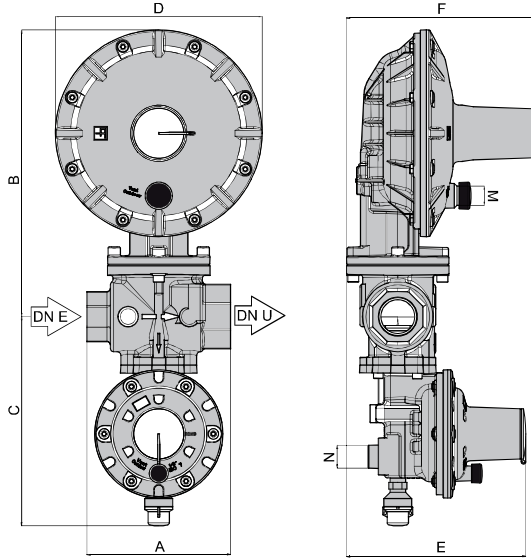

Overall dimensions in mm

Dival 500 + LA		
	Dival 500 + LA 1"x1"	Dival 500 + LA 1"x1 1/2"
A	100±1	130±1
B	255	257
C	182	182
D	185.5	185.5
E	161	161
F	173	173
N	1/4"	1/4"
M	1/4"	1/4"
DnE	1"ISO 7/1	1"ISO 7/1
DnU	1"ISO 7/1	1 1/2 ISO 7/1

Weights in KGF

	25	40
Inches	1"	1 1/2"
Dival 500 + LA	4.2	4.4

INDUSTRIAL VALVE SOLUTION
MIX **FLOW**
Grupa Baltina www.mixflow.com.pl

MIXFLOW – ENERGY
PL 80 – 314 Gdańsk,
Al. Grunwaldzka 303
Tel: +48 58 676 55 39
info@mixflow.com.pl



The data are not binding.
We reserve the right to
make changes without prior
notice.

